

QM MAX GII **GMX/MXG Type**

Achieving high metal removal rates! High efficiency machining for versatile applications



Q=317cm³/min
(when using Dc50-7N)



Feature 1

Optimized cutting edge for a wide range of applications

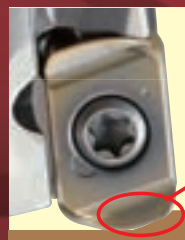

ENMU Type
For high feed with chipbreaker

Double sided insert



ENMQ Type
For hard materials

Feature 2

Economical double sided insert with 4 cutting edges
For various types of materials ; Carbon steel, Hardened material <upto 62HRC>, Stainless steel, Titanium alloy

● Line up



ENMU100412ZER-SL

- Low cutting force
- Sharp cutting edge
- Grade C7550, JC7518
- DS118, DS150

ENMU100412ZER-PH

- For general applications
- Grade JC8118, JC8050, JC7560

ENMU100312ZER-HL

- For hardened materials up to 60HRC
- enhanced cutting edge strength but retains sharpness
- Grade DH102

ENMQ100312ZER

- Flat top insert
- Grade DH102
- For hardened materials over 60HRC

● Insert grades

Iso	P					M					K				S				H			
	P01	P10	P20	P30	P40	M01	M10	M20	M30	M40	K01	K10	K20	K30	S01	S10	S20	S30	H01	H10	H20	
Range																	DS118					
																	DS150					
			JC8118					JC8118			DH102		JC8118				DH102				DH102	
			JC8050					JC8050					JC8050				JC8050					JC8118
			JC7518					JC7518					JC7518				JC7518					JC7518
			JC7550					JC7550					JC7550				JC7550					
		JC7560					JC7560					JC7560				JC7560						

QM MAX GII **GMX/MXG Type**

■ **Facemill Type**

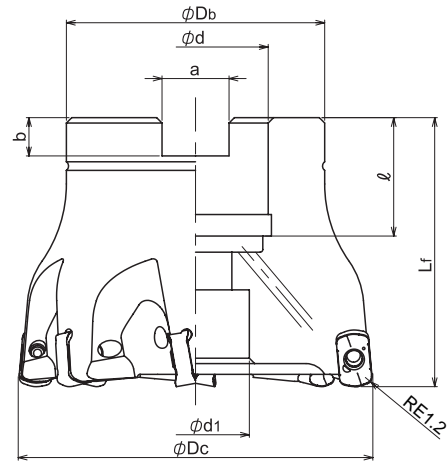

Cat.No	Stock	No. of inserts	Dimensions (mm)							Weight (kg)	Inserts	
			ϕD_c	L_f	ϕD_b	ϕd	ϕd_1	a	b			ℓ
GMX-7050R-22	●	7	50	50	40	22	17	10.4	6.3	20	0.35	ENMU100412ZER-**, ENM*100312ZER-**
GMX-7052R-22	●		52								0.40	
GMX-7063R-22	●		63								0.64	
GMX-7066R-27	●		66	48	27	20	12.4	7	22	0.66		

Screw	Torque(N.m)	Wrench
TSW-2567H	1.1	A-08

QM MAX GII **GMX/MXG Type**

■ Endmill Shank Type

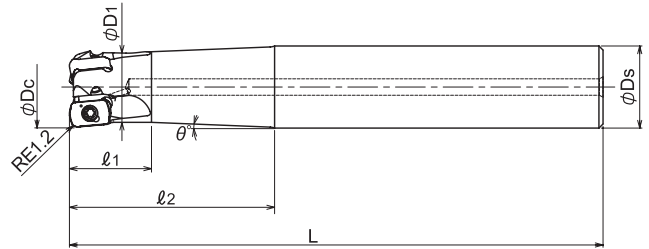

Cat.No	Stock	No. of inserts	Dimensions (mm)						θ° taper angle	Inserts
			φDc	l1	l2	L	φD1	φDs		
GMX-2016-30-S16	●	2	16	16	30	100	14	16	3.5°	ENMU100412ZER-**; ENM*100312ZER-**
GMX-2016-50-S16	●				50	150			1.2°	
GMX-3020-50-S20	●	3	20	20	130	17.2	20	2.3°		
GMX-3020-80-S20	●				80			160	1°	
GMX-4025-60-S25	●	4	25	25	60	140	22	25	2°	
GMX-4025-100-S25	●				100				180	
GMX-5032-70-S32	●	5	32	30	70	150	29	32	1.5°	
GMX-5032-120-S32	●				120				200	

Screw	Torque(N.m)	Wrench
TSW-2567H	1.1	A-08

QM MAX GII **GMX/MXG Type**

■ **Modular Head Type**



Through coolant hole

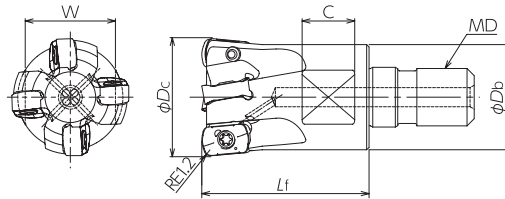
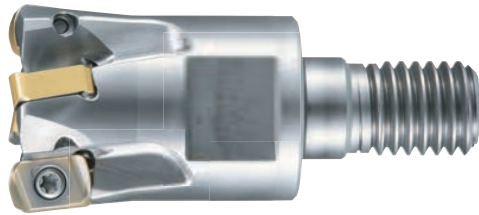

Cat.No	Stock	No. of inserts	Dimensions (mm)						Inserts	
			φDc	Lf	φDb	MD	C	W		
MXG-2016-M8	●	2	16	23	14	M8	8	12	ENMU100412ZER-**; ENM*100312ZER-**	
MXG-2017-M8	●		17			M8				
MXG-3020-M10	●	3	20	30	18	M10	9	14		
MXG-3021-M10	●		21			M10				
MXG-3025-M12	●	4	25	35	22	M12	11	19		
MXG-4025-M12	●		26			M12				
MXG-4026-M12	●					22.5				M12
MXG-4028-M12	●					23.6				M12
MXG-5030-M16	●	5	30	43	27	M16	12	22		
MXG-5032-M16	●		32			29				M16
MXG-5035-M16	●		35							M16
MXG-6040-M16	●	6	40	43	32	M16	14	26		
MXG-6042-M16	●		42			M16				

Screw	Torque(N.m)	Wrench
TSW-2567H	1.1	A-08

QM MAX GII **GMX/MXG Type**

■ **Insert**

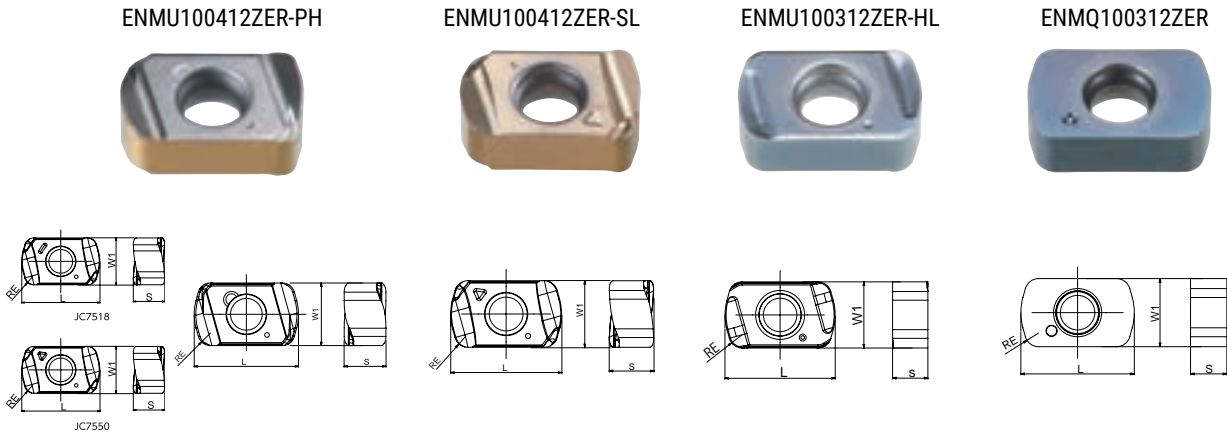

Cat.No	Tolerance	PVD Coating							Dimensions (mm)				
		DH102	JC7518	JC7550	JC7560	JC8050	JC8118	DS118	DS150	RE	L	W1	S
ENMU100412ZER-PH	M				●	●	●			1.2	10	6	4
ENMU100412ZER-SL			●	●				●	●				3.2
ENMU100312ZER-HL		●											
ENMQ100312ZER		●											

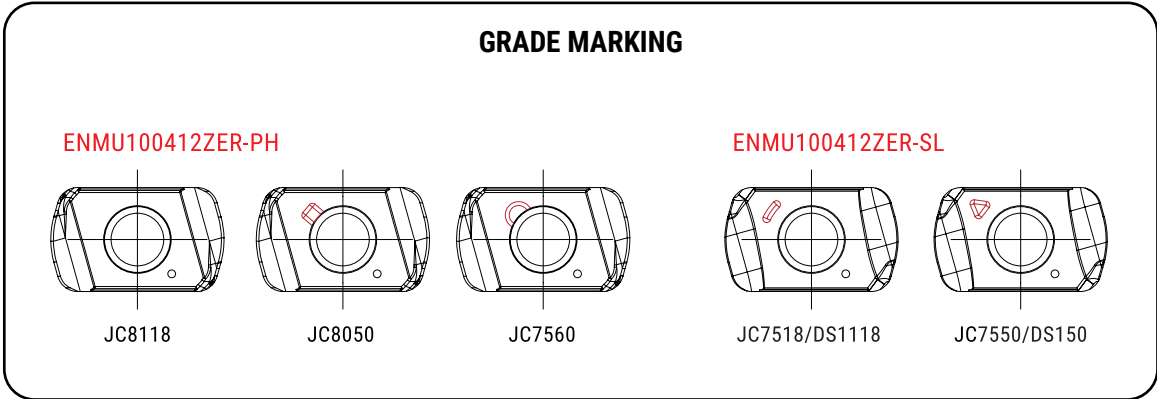

QM MAX GII

GMX/MXG Type

■ Insert selection guide

Materials	Grade	Cat.No.			
		ENMU100412ZER-PH For general milling	ENMU100412ZER-SL Low cutting force	ENMU100312ZER-HL For Hardened materials	ENMQ100312ZER Flat top insert
Carbon steel (S50C, S55C) below 250HB	JC8118	○			
	JC8050	◎			
	JC7560	●			
	JC7550				
	JC7518		☆		
	DH102				
	DS118				
	DS150				
Tool & die steel (SKD61, SKD11) below 255HB	JC8118	○			
	JC8050	◎			
	JC7560	●			
	JC7550				
	JC7518		☆		
	DH102				
	DS118				
	DS150				
Mold steel HPM7, PX5, P20) 30 - 36HRC	JC8118	○			
	JC8050	◎			
	JC7560	●			
	JC7550				
	JC7518		☆		
	DH102				
	DS118				
	DS150				
Mold steel (NAK80, HPM1, P21) 38 - 43HRC	JC8118	◎			
	JC8050	●			
	JC7560				
	JC7550				
	JC7518		☆		
	DH102				
	DS118				
	DS150				
Hardened die steel (SKD61, DAC, DHA) 42 - 52HRC	JC8118	◎			
	JC8050				
	JC7560				
	JC7550				
	JC7518		☆		
	DH102			●	
	DS118				
	DS150				
Hardened die steel (SKD11, SLD, DC11) 55 - 62HRC	JC8118	×			
	JC8050	×			
	JC7560	×			
	JC7550		×		
	JC7518		×		
	DH102			○	◎
	DS118				
	DS150				
Grey cast iron (FC, FCD) below 300HB	JC8118	◎			
	JC8050	○			
	JC7560	●			
	JC7550				
	JC7518				
	DH102				
	DS118				
	DS150				
Stainless steel (SUS304) below 250HB	JC8118	●			
	JC8050				
	JC7560				
	JC7550		○		
	JC7518				
	DH102				
	DS118				
	DS150		◎		
Titanium alloy (Ti-6Al-4V)	JC8118	●			
	JC8050				
	JC7560				
	JC7550		○		
	JC7518				
	DH102				
	DS118				
	DS150		◎		
Heat resistant alloy (INCO718)	JC8118	●			
	JC8050				
	JC7560				
	JC7550				
	JC7518		○		
	DH102				
	DS118		◎		
	DS150				

◎ : First choice ○ : For general milling ● : For unstable milling ☆ : For light cutting resistance × : Not recommended

QM MAX GII

GMX/MXG Type

Definition of Corner Shape for Programming

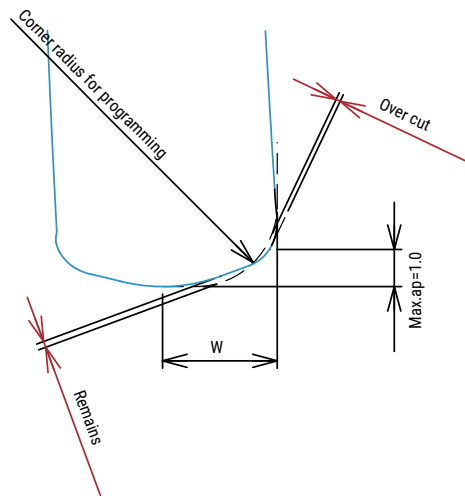

Cat.No.	W	Corner radius for programming	Remains	Over cut
ENMU100412ZER-PH ENMU100412ZER-SL	3.1	1.0	0.51	0
		1.5 (Standard)	0.36	0
		2.0	0.22	0.05

(mm)

Cat.No.	W	Corner radius for programming	Remains	Over cut
ENMU100312ZER-HL ENMQ100312ZER	3.3	1.0	0.55	0
		1.5 (Standard)	0.41	0
		2.0	0.26	0.04

(mm)

QM MAX GII

GMX/MXG Type

Recommended Data for Profile Milling

Ramping

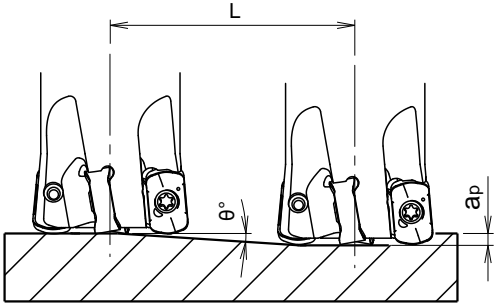

Helical interpolation

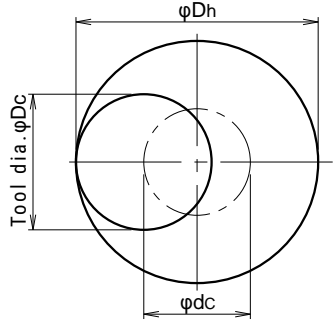

● Calculation of tool pass dia.

$$\varphi_{dc} = \varphi_{Dh} - \varphi_{Dc}$$

Tool pass dia. Bore dia. Tool dia.

● Depth of cut per one circuit should not exceed max. depth of cut Ap

● Down cutting is recommended, tool pass rotation should be counterclockwise

- In case of ramping and helical interpolation, apply 70% or less feed (Vf) from standard cutting condition table
- In case of drilling, apply 50% or less Z axis feed (F) from standard cutting condition table
- Long consecutive chips may result in case of drilling, confirm safe operating conditions

Cat.No.	Tool dia.	Effective Cutting dia.		Max. depth of cut: ap	Ramping	
		Insert			Ramping Max. ramping Angle θ	Max. depth of cut (ap) Total cutting length:L (mm)
		ENMU100412ZER-***	ENM***100312ZER-***			
MXG-2016-M8	16	10.1	9.6	0.7	1°36'	25.1
MXG-2017-M8	17	11	10.5	0.7	1°36'	25.1
MXG-3020-M10	20	13.9	13.5	1	1°30'	38.2
MXG-3021-M10	21	14.9	14.5	1	1°30'	38.2
MXG-*025-M12	25	18.9	18.4	1	1°12'	47.7
MXG-4026-M12	26	19.9	19.4	1	1°12'	47.7
MXG-5030-M16	30	23.9	23.4	1	0°54'	63.6
MXG-5032-M16	32	25.8	25.4	1	0°54'	63.6
MXG-5035-M16	35	28.8	28.4	1	0°42'	81.8
MXG-6040-M16	40	33.8	33.4	1	0°30'	114.5
MXG-6042-M16	42	35.8	35.4	1	0°30'	114.5
GMX-2016-**-S16	16	10.1	9.6	0.7	1°36'	25.1
GMX-3020-**-S20	20	13.9	13.5	1	1°30'	38.2
GMX-4025-**-S25	25	18.9	18.4	1	1°12'	47.7
GMX-5032-**-S32	32	25.8	25.4	1	0°54'	63.6
GMX-7050R-**	50	43.8	43.4	1	0°24'	143.2
GMX-7052R-22	52	45.8	45.4	1	0°24'	143.2
GMX-7063R-**	63	56.8	56.4	1	0°18'	190.9
GMX-7066R-**	66	59.8	59.4	1	0°18'	190.9

Cat.No.	Tool dia.	Helical interpolation			Max.drilling depth : Z	
		Min.Bore dia.		Max. Bore dia.	Insert	
		ENMU100412ZER-***	ENM***100312ZER-***		ENMU100412ZER-***	ENM***100312ZER-***
MXG-2016-M8	16	22	21	30	0.3	0.2
MXG-2017-M8	17	24	23	32	0.3	0.2
MXG-3020-M10	20	30	29	38	0.4	0.2
MXG-3021-M10	21	32	31	40	0.4	0.2
MXG-*025-M12	25	40	39	48	0.5	0.3
MXG-4026-M12	26	42	41	50	0.5	0.3
MXG-5030-M16	30	50	49	58	0.6	0.4
MXG-5032-M16	32	54	53	62	0.6	0.4
MXG-5035-M16	35	60	59	68	0.6	0.4
MXG-6040-M16	40	70	69	78	0.7	0.5
MXG-6042-M16	42	74	73	82	0.7	0.5
GMX-2016-**-S16	16	22	21	30	0.3	0.2
GMX-3020-**-S20	20	30	29	38	0.4	0.2
GMX-4025-**-S25	25	40	39	48	0.5	0.3
GMX-5032-**-S32	32	54	53	62	0.6	0.4
GMX-7050R-**	50	90	89	98	0.8	0.6
GMX-7052R-22	52	94	93	102	0.8	0.6
GMX-7063R-**	63	116	115	124	0.8	0.6
GMX-7066R-**	66	122	121	130	0.8	0.6

QM MAX GII**GMX/MXG Type**

■ Recommended cutting conditions

● Modular Head Type + MSN shank

Material	Cat.No.	Grade	Tool dia.(mm)									
			16/17					20/21/28				
			2N					3N				
			ℓ (mm)	ap (mm)	ae (mm)	n (min ⁻¹)	Vf (mm/min)	ℓ (mm)	ap (mm)	ae (mm)	n (min ⁻¹)	Vf (mm/min)
Carbon steel (S50C, S55C) below 250HB	ENMU 100412 ZER-PH	JC8050 (JC7560)	~50	0.7	~10	3,580	8,590	~60	0.8	~14	2,860	10,300
			80	0.6	~10	3,580	8,590	100	0.6	~14	2,860	10,300
			120	0.6	~10	3,180	7,630	140	0.6	~14	2,550	9,180
Tool & die steel (SKD61, SKD11) below 255HB	ENMU 100412 ZER-PH	JC8050 (JC7560)	~50	0.7	~10	3,580	8,590	~60	0.8	~14	2,860	10,300
			80	0.6	~10	3,580	8,590	100	0.6	~14	2,860	10,300
			120	0.6	~10	3,180	7,630	140	0.6	~14	2,550	9,180
Mold steel (HPM7, PX5, P20) 30-36 HRC	ENMU 100412 ZER-PH	JC8050 (JC7560)	~50	0.7	~10	3,180	7,630	~60	0.8	~14	2,550	9,180
			80	0.6	~10	3,180	7,630	100	0.6	~14	2,550	9,180
			120	0.6	~10	2,590	6,220	140	0.6	~14	2,070	7,450
Mold steel (NAK80, HPM1, P21) 38-43HRC	ENMU 100412 ZER-PH	JC8118 (JC8050)	~50	0.6	~10	1,890	4,160	~60	0.6	~14	1,510	4,980
			80	0.5	~10	1,690	3,040	100	0.5	~14	1,350	3,650
			120	0.5	~10	1,590	2,860	140	0.5	~14	1,270	3,430
Hardened die steel (SKD61, DAC, DHA) 42-52HRC	ENMU100412 ZER-PH (ENMU100412 ZER-SL)	JC8118 (JC7518)	~50	0.6	~10	1,890	4,160	~60	0.6	~14	1,510	4,980
			80	0.5	~10	1,690	3,040	100	0.5	~14	1,350	3,650
			120	0.5	~10	1,590	2,860	140	0.5	~14	1,270	3,430
Hardened die steel (SKD11, SLD, DC11) 55-62HRC	ENMQ100312 ZER (ENMU100312 ZER-HL)	DH102	~50	0.2	~10	1,590	950	~60	0.2	~14	1,270	1,140
			80	0.15	~10	1,390	700	100	0.15	~14	1,110	830
			120	0.1	~10	1,290	650	140	0.1	~14	1,030	770
Grey cast iron (FC250) 160-260HB	ENMU 100412 ZER-PH	JC8118 (JC8050)	~50	0.7	~10	3,980	11,940	~60	1	~14	3,180	14,310
			80	0.7	~10	3,980	11,940	100	0.8	~14	3,180	14,310
			120	0.6	~10	3,580	8,590	140	0.6	~14	2,860	10,300
Nodular cast iron (FCD700) 170-300HB	ENMU 100412 ZER-PH	JC8118 (JC8050)	~50	0.7	~10	3,980	11,940	~60	1	~14	3,180	14,310
			80	0.7	~10	3,980	11,940	100	0.8	~14	3,180	14,310
			120	0.6	~10	3,580	8,590	140	0.6	~14	2,860	10,300
Austenitic stainless steel (SUS304, 316, 317) 17Cr	ENMU 100412 ZER-SL	JC7550 (JC7518)	~50	0.6	~10	2,390	4,780	~60	0.6	~14	1,910	5,730
			80	0.5	~10	2,390	4,780	100	0.5	~14	1,910	5,730
			120	0.5	~10	1,990	3,180	140	0.5	~14	1,590	3,820
Precipitation hardening stainless steel (SUS630)	ENMU100412 ZER-SL ENMU100412 ZER-PH	JC7550 (JC8050)	~50	0.5	~10	1,990	2,790	~60	0.5	~14	1,590	3,340
			80	0.4	~10	1,990	2,790	100	0.4	~14	1,590	3,340
			120	0.4	~10	1,790	2,150	140	0.4	~14	1,430	2,570
Duplex stainless steel (S32750)	ENMU100412 ZER-SL ENMU100412 ZER-PH	JC7550 (JC8050)	~50	0.6	~10	1,990	1,190	~60	0.6	~14	1,590	1,430
			80	0.5	~10	1,990	1,190	100	0.5	~14	1,590	1,430
			120	0.5	~10	1,790	720	140	0.5	~14	1,430	860
Titanium alloy (Ti-6Al-4V) 35-43HRC	ENMU 100412 ZER-SL	DS150 (DS118)	~50	0.5	~10	1,190	1,670	~60	0.5	~14	950	2,000
			80	0.4	~10	1,190	1,670	100	0.4	~14	950	2,000
			120	0.4	~10	990	1,190	140	0.4	~14	800	1,440
Heat resistant alloy (INCO718) 35-43HRC	ENMU 100412 ZER-SL	DS118 (DS150)	~50	0.5	~10	600	360	~60	0.5	~14	480	430
			80	0.3	~10	600	360	100	0.3	~14	480	430
			120	0.2	~10	600	360	140	0.2	~14	480	430

Note

1. Please adjust cutting conditions according to machine rigidity or work rigidity.
2. In case of chatter occurring, recommended to reduce ap or rpm and keep feed per tooth.
3. ap should be reduced when using on low rigidity machine.
4. Use air blow.

QM MAX GII**GMX/MXG Type**

■ Recommended cutting conditions

● Modular Head Type + MSN shank

Material	Cat.No.	Grade	Tool dia.(mm)									
			25					25/26				
			3N					4N				
			ℓ (mm)	ap (mm)	ae (mm)	n (min ⁻¹)	Vf (mm/min)	ℓ (mm)	ap (mm)	ae (mm)	n (min ⁻¹)	Vf (mm/min)
Carbon steel (S50C, S55C) below 250HB	ENMU 100412 ZER-PH	JC8050 (JC7560)	~75	0.8	~19	2,290	8,240	~75	0.8	~19	2,290	10,990
			125	0.6	~19	2,290	8,240	125	0.6	~19	2,290	10,990
			175	0.6	~19	2,040	7,340	175	0.6	~19	2,040	9,790
Tool & die steel (SKD61, SKD11) below 255HB	ENMU 100412 ZER-PH	JC8050 (JC7560)	~75	0.8	~19	2,290	8,240	~75	0.8	~19	2,290	10,990
			125	0.6	~19	2,290	8,240	125	0.6	~19	2,290	10,990
			175	0.6	~19	2,040	7,340	175	0.6	~19	2,040	9,790
Mold steel (HPM7, PX5, P20) 30-36 HRC	ENMU 100412 ZER-PH	JC8050 (JC7560)	~75	0.8	~19	2,040	7,340	~75	0.8	~19	2,040	9,790
			125	0.6	~19	2,040	7,340	125	0.6	~19	2,040	9,790
			175	0.6	~19	1,660	5,980	175	0.6	~19	1,660	7,970
Mold steel (NAK80, HPM1, P21) 38-43HRC	ENMU 100412 ZER-PH	JC8118 (JC8050)	~75	0.6	~19	1,210	3,990	~75	0.6	~19	1,210	5,320
			125	0.5	~19	1,080	2,920	125	0.5	~19	1,080	3,890
			175	0.5	~19	1,020	2,750	175	0.5	~19	1,020	3,670
Hardened die steel (SKD61, DAC, DHA) 42-52HRC	ENMU100412 ZER-PH (ENMU100412 ZER-SL)	JC8118 (JC7518)	~75	0.6	~19	1,210	3,990	~75	0.6	~19	1,210	5,320
			125	0.5	~19	1,080	2,920	125	0.5	~19	1,080	3,890
			175	0.5	~19	1,020	2,750	175	0.5	~19	1,020	3,670
Hardened die steel (SKD11, SLD, DC11) 55-62HRC	ENMQ100312 ZER (ENMU100312 ZER-HL)	DH102	~75	0.2	~19	1,020	920	~75	0.2	~19	1,020	1,220
			125	0.15	~19	890	670	125	0.15	~19	890	890
			175	0.1	~19	830	620	175	0.1	~19	830	830
Grey cast iron (FC250) 160-260HB	ENMU 100412 ZER-PH	JC8118 (JC8050)	~75	1	~19	2,550	11,480	~75	1	~19	2,550	15,300
			125	0.8	~19	2,550	11,480	125	0.8	~19	2,550	15,300
			175	0.6	~19	2,290	8,240	175	0.6	~19	2,290	10,990
Nodular cast iron (FCD700) 170-300HB	ENMU 100412 ZER-PH	JC8118 (JC8050)	~75	1	~19	2,550	11,480	~75	1	~19	2,550	15,300
			125	0.8	~19	2,550	11,480	125	0.8	~19	2,550	15,300
			175	0.6	~19	2,290	8,240	175	0.6	~19	2,290	10,990
Austenitic stainless steel (SUS304, 316, 317) 17Cr	ENMU 100412 ZER-SL	JC7550 (JC7518)	~75	0.6	~19	1,530	4,590	~75	0.6	~19	1,530	6,120
			125	0.5	~19	1,530	4,590	125	0.5	~19	1,530	6,120
			175	0.5	~19	1,270	3,050	175	0.5	~19	1,270	4,060
Precipitation hardening stainless steel (SUS630)	ENMU100412 ZER-SL ENMU100412 ZER-PH	JC7550 (JC8050)	~75	0.5	~19	1,270	2,670	~75	0.5	~19	1,270	3,560
			125	0.4	~19	1,270	2,670	125	0.4	~19	1,270	3,560
			175	0.4	~19	1,150	2,070	175	0.4	~19	1,150	2,760
Duplex stainless steel (S32750)	ENMU100412 ZER-SL ENMU100412 ZER-PH	JC7550 (JC8050)	~75	0.6	~19	1,270	1,140	~75	0.6	~19	1,270	1,520
			125	0.5	~19	1,270	1,140	125	0.5	~19	1,270	1,520
			175	0.5	~19	1,150	690	175	0.5	~19	1,150	920
Titanium alloy (Ti-6Al-4V) 35-43HRC	ENMU 100412 ZER-SL	DS150 (DS118)	~75	0.5	~19	760	1,600	~75	0.5	~19	760	2,130
			125	0.4	~19	760	1,600	125	0.4	~19	760	2,130
			175	0.4	~19	640	1,150	175	0.4	~19	640	1,540
Heat resistant alloy (INCO718) 35-43HRC	ENMU 100412 ZER-SL	DS118 (DS150)	~75	0.5	~19	380	340	~75	0.5	~19	380	460
			125	0.3	~19	380	340	125	0.3	~19	380	460
			175	0.2	~19	380	340	175	0.2	~19	380	460

Note

1. Please adjust cutting conditions according to machine rigidity or work rigidity.
2. In case of chatter occurring, recommended to reduce ap or rpm and keep feed per tooth.
3. ap should be reduced when using on low rigidity machine.
4. Use air blow.

QM MAX GII**GMX/MXG Type**

■ Recommended cutting conditions

● Modular Head Type + MSN shank

Material	Cat.No.	Grade	Tool dia.(mm)									
			30/32/35					40/42				
			5N					6N				
			φ (mm)	a _p (mm)	a _e (mm)	n (min ⁻¹)	V _f (mm/min)	φ (mm)	a _p (mm)	a _e (mm)	n (min ⁻¹)	V _f (mm/min)
Carbon steel (S50C, S55C) below 250HB	ENMU 100412 ZER-PH	JC8050 (JC7560)	~90	0.8	~25	1,910	11,460	~120	0.8	~32	1,430	10,300
			150	0.6	~25	1,910	11,460	200	0.6	~32	1,430	10,300
			210	0.6	~25	1,700	10,200	280	0.6	~32	1,270	9,140
Tool & die steel (SKD61, SKD11) below 255HB	ENMU 100412 ZER-PH	JC8050 (JC7560)	~90	0.8	~25	1,910	11,460	~120	0.8	~32	1,430	10,300
			150	0.6	~25	1,910	11,460	200	0.6	~32	1,430	10,300
			210	0.6	~25	1,700	10,200	280	0.6	~32	1,270	9,140
Mold steel (HPM7, PX5, P20) 30-36 HRC	ENMU 100412 ZER-PH	JC8050 (JC7560)	~90	0.8	~25	1,700	10,200	~120	0.8	~32	1,270	9,140
			150	0.6	~25	1,700	10,200	200	0.6	~32	1,270	9,140
			210	0.6	~25	1,380	8,280	280	0.6	~32	1,030	7,420
Mold steel (NAK80, HPM1, P21) 38-43HRC	ENMU 100412 ZER-PH	JC8118 (JC8050)	~90	0.6	~25	1,010	5,560	~120	0.6	~32	760	5,020
			150	0.5	~25	900	4,050	200	0.5	~32	680	3,670
			210	0.5	~25	850	3,830	280	0.5	~32	640	3,460
Hardened die steel (SKD61, DAC, DHA) 42-52HRC	ENMU100412 ZER-PH (ENMU100412 ZER-SL)	JC8118 (JC7518)	~90	0.6	~25	1,010	5,560	~120	0.6	~32	760	5,020
			150	0.5	~25	900	4,050	200	0.5	~32	680	3,670
			210	0.5	~25	850	3,830	280	0.5	~32	640	3,460
Hardened die steel (SKD11, SLD, DC11) 55-62HRC	ENMQ100312 ZER (ENMU100312 ZER-HL)	DH102	~90	0.2	~25	850	1,280	~120	0.2	~32	640	1,150
			150	0.15	~25	740	930	200	0.15	~32	560	840
			210	0.1	~25	690	860	280	0.1	~32	520	780
Grey cast iron (FC250) 160-260HB	ENMU 100412 ZER-PH	JC8118 (JC8050)	~90	1	~25	2,120	15,900	~120	1	~32	1,590	14,310
			150	0.8	~25	2,120	15,900	200	0.8	~32	1,590	14,310
			210	0.6	~25	1,910	11,460	280	0.6	~32	1,430	10,300
Nodular cast iron (FCD700) 170-300HB	ENMU 100412 ZER-PH	JC8118 (JC8050)	~90	1	~25	2,120	15,900	~120	1	~32	1,590	14,310
			150	0.8	~25	2,120	15,900	200	0.8	~32	1,590	14,310
			210	0.6	~25	1,910	11,460	280	0.6	~32	1,430	10,300
Austenitic stainless steel (SUS304, 316, 317) 17Cr	ENMU 100412 ZER-SL	JC7550 (JC7518)	~90	0.6	~25	1,270	6,350	~120	0.6	~32	950	5,700
			150	0.5	~25	1,270	6,350	200	0.5	~32	950	5,700
			210	0.5	~25	1,060	4,240	280	0.5	~32	800	3,840
Precipitation hardening stainless steel (SUS630)	ENMU100412 ZER-SL ENMU100412 ZER-PH	JC7550 (JC8050)	~90	0.5	~25	1,060	3,710	~120	0.5	~32	800	3,360
			150	0.4	~25	1,060	3,710	200	0.4	~32	800	3,360
			210	0.4	~25	950	2,850	280	0.4	~32	720	2,590
Duplex stainless steel (S32750)	ENMU100412 ZER-SL ENMU100412 ZER-PH	JC7550 (JC8050)	~90	0.6	~25	1,060	1,590	~120	0.6	~32	800	1,440
			150	0.5	~25	1,060	1,590	200	0.5	~32	800	1,440
			210	0.5	~25	950	950	280	0.5	~32	720	860
Titanium alloy (Ti-6Al-4V) 35-43HRC	ENMU 100412 ZER-SL	DS150 (DS118)	~90	0.5	~25	640	2,240	~120	0.5	~32	480	2,020
			150	0.4	~25	640	2,240	200	0.4	~32	480	2,020
			210	0.4	~25	530	1,590	280	0.4	~32	400	1,440
Heat resistant alloy (INCO718) 35-43HRC	ENMU 100412 ZER-SL	DS118 (DS150)	~90	0.5	~25	320	480	~120	0.5	~32	240	430
			150	0.3	~25	320	480	200	0.3	~32	240	430
			210	0.2	~25	320	480	280	0.2	~32	240	430

Note

1. Please adjust cutting conditions according to machine rigidity or work rigidity.
2. In case of chatter occurring, recommended to reduce a_p or rpm and keep feed per tooth.
3. a_p should be reduced when using on low rigidity machine.
4. Use air blow.

QM MAX GII**GMX/MXG Type**

■ Recommended cutting conditions

● Endmill Type

Material	Cat.No.	Grade	Tool dia.(mm)									
			16					20				
			2N					3N				
			ϕ (mm)	a_p (mm)	a_e (mm)	n (min ⁻¹)	V_f (mm/min)	ϕ (mm)	a_p (mm)	a_e (mm)	n (min ⁻¹)	V_f (mm/min)
Carbon steel (S50C, S55C) below 250HB	ENMU 100412 ZER-PH	JC8050 (JC7560)	~30	0.7	~10	3,580	8,590					
			30~50	0.6	~10	3,580	8,590	~60	0.6	~14	2,860	10,300
			50~70	0.6	~10	3,180	7,630	60~100	0.6	~14	2,550	9,180
Tool & die steel (SKD61, SKD11) below 255HB	ENMU 100412 ZER-PH	JC8050 (JC7560)	~30	0.7	~10	3,580	8,590					
			30~50	0.6	~10	3,580	8,590	~60	0.6	~14	2,860	10,300
			50~70	0.6	~10	3,180	7,630	60~100	0.6	~14	2,550	9,180
Mold steel (HPM7, PX5, P20) 30-36 HRC	ENMU 100412 ZER-PH	JC8050 (JC7560)	~30	0.7	~10	3,180	7,630					
			30~50	0.6	~10	3,180	7,630	~60	0.6	~14	2,550	9,180
			50~70	0.6	~10	2,590	6,220	60~100	0.6	~14	2,070	7,450
Mold steel (NAK80, HPM1, P21) 38-43HRC	ENMU 100412 ZER-PH	JC8118 (JC8050)	~30	0.6	~10	1,890	4,160					
			30~50	0.5	~10	1,690	3,040	~60	0.5	~14	1,350	3,650
			50~70	0.5	~10	1,590	2,860	60~100	0.5	~14	1,270	3,430
Hardened die steel (SKD61, DAC, DHA) 42-52HRC	ENMU100412 ZER-PH (ENMU100412 ZER-SL)	JC8118 (JC7518)	~30	0.6	~10	1,890	4,160					
			30~50	0.5	~10	1,690	3,040	~60	0.5	~14	1,350	3,650
			50~70	0.5	~10	1,590	2,860	60~100	0.5	~14	1,270	3,430
Hardened die steel (SKD11, SLD, DC11) 55-62HRC	ENMU100312 ZER (ENMU100312 ZER-HL)	DH102	~30	0.2	~10	1,590	950					
			30~50	0.15	~10	1,390	700	~60	0.15	~14	1,110	830
			50~70	0.1	~10	1,290	650	60~100	0.1	~14	1,030	770
Grey cast iron (FC250) 160-260HB	ENMU 100412 ZER-PH	JC8118 (JC8050)	~30	0.7	~10	3,980	11,940					
			30~50	0.7	~10	3,980	11,940	~60	0.8	~14	3,180	14,310
			50~70	0.6	~10	3,580	8,590	60~100	0.6	~14	2,860	10,300
Nodular cast iron (FCD700) 170-300HB	ENMU 100412 ZER-PH	JC8118 (JC8050)	~30	0.7	~10	3,980	11,940					
			30~50	0.7	~10	3,980	11,940	~60	0.8	~14	3,180	14,310
			50~70	0.6	~10	3,580	8,590	60~100	0.6	~14	2,860	10,300
Austenitic stainless steel (SUS304, 316, 317) 17Cr	ENMU 100412 ZER-SL	JC7550 (JC7518)	~30	0.6	~10	2,390	4,780					
			30~50	0.5	~10	2,390	4,780	~60	0.5	~14	1,910	5,730
			50~70	0.5	~10	1,990	3,180	60~100	0.5	~14	1,590	3,820
Precipitation hardening stainless steel (SUS630)	ENMU100412 ZER-SL ENMU100412 ZER-PH	JC7550 (JC8050)	~30	0.5	~10	1,990	2,790					
			30~50	0.4	~10	1,990	2,790	~60	0.4	~14	1,590	3,340
			50~70	0.4	~10	1,790	2,150	60~100	0.4	~14	1,430	2,570
Duplex stainless steel (S32750)	ENMU100412 ZER-SL ENMU100412 ZER-PH	JC7550 (JC8050)	~30	0.6	~10	1,990	1,190					
			30~50	0.5	~10	1,990	1,190	~60	0.5	~14	1,590	1,430
			50~70	0.5	~10	1,790	720	60~100	0.5	~14	1,430	860
Titanium alloy (Ti-6Al-4V) 35-43HRC	ENMU 100412 ZER-SL	DS150 (DS118)	~30	0.5	~10	1,190	1,670					
			30~50	0.4	~10	1,190	1,670	~60	0.4	~14	950	2,000
			50~70	0.4	~10	990	1,190	60~100	0.4	~14	800	1,440
Heat resistant alloy (INCO718) 35-43HRC	ENMU 100412 ZER-SL	DS118 (DS150)	~30	0.5	~10	600	360					
			30~50	0.3	~10	600	360	~60	0.3	~14	480	430
			50~70	0.2	~10	600	360	60~100	0.2	~14	480	430

Note

1. Please adjust cutting conditions according to machine rigidity or work rigidity.
2. In case of chatter occurring, recommended to reduce a_p or rpm and keep feed per tooth.
3. a_p should be reduced when using on low rigidity machine.
4. Use air blow.

QM MAX GII**GMX/MXG Type**

■ Recommended cutting conditions

● Endmill Type

Material	Cat.No.	Grade	Tool dia.(mm)									
			25					32				
			4N					5N				
			ℓ (mm)	a_p (mm)	a_e (mm)	n (min ⁻¹)	V_f (mm/min)	ℓ (mm)	a_p (mm)	a_e (mm)	n (min ⁻¹)	V_f (mm/min)
Carbon steel (S50C, S55C) below 250HB	ENMU 100412 ZER-PH	JC8050 (JC7560)	~70	0.6	~19	2,290	10,990	~90	0.6	~25	1,790	10,740
			70~120	0.6	~19	2,040	9,790	90~140	0.6	~25	1,590	9,540
Tool & die steel (SKD61, SKD11) below 255HB	ENMU 100412 ZER-PH	JC8050 (JC7560)	~70	0.6	~19	2,290	10,990	~90	0.6	~25	1,790	10,740
			70~120	0.6	~19	2,040	9,790	90~140	0.6	~25	1,590	9,540
Mold steel (HPM7, PX5, P20) 30-36 HRC	ENMU 100412 ZER-PH	JC8050 (JC7560)	~70	0.6	~19	2,040	9,790	~90	0.6	~25	1,590	9,540
			70~120	0.6	~19	1,660	7,970	90~140	0.6	~25	1,290	7,740
Mold steel (NAK80, HPM1, P21) 38-43HRC	ENMU 100412 ZER-PH	JC8118 (JC8050)	~70	0.5	~19	1,080	3,890	~90	0.5	~25	850	3,830
			70~120	0.5	~19	1,020	3,670	90~140	0.5	~25	800	3,600
Hardened die steel (SKD61, DAC, DHA) 42-52HRC	ENMU100412 ZER-PH (ENMU100412 ZER-SL)	JC8118 (JC7518)	~70	0.5	~19	1,080	3,890	~90	0.5	~25	850	3,830
			70~120	0.5	~19	1,020	3,670	90~140	0.5	~25	800	3,600
Hardened die steel (SKD11, SLD, DC11) 55-62HRC	ENMQ100312 ZER (ENMU100312 ZER-HL)	DH102	~70	0.15	~19	890	890	~90	0.15	~25	700	880
			70~120	0.1	~19	830	830	90~140	0.1	~25	650	810
Grey cast iron (FC250) 160-260HB	ENMU 100412 ZER-PH	JC8118 (JC8050)	~70	0.8	~19	2,550	15,300	~90	0.8	~25	1,990	14,930
			70~120	0.6	~19	2,290	10,990	90~140	0.6	~25	1,790	10,740
Nodular cast iron (FCD700) 170-300HB	ENMU 100412 ZER-PH	JC8118 (JC8050)	~70	0.8	~19	2,550	15,300	~90	0.8	~25	1,990	14,930
			70~120	0.6	~19	2,290	10,990	90~140	0.6	~25	1,790	10,740
Austenitic stainless steel (SUS304, 316, 317) 17Cr	ENMU 100412 ZER-SL	JC7550 (JC7518)	~70	0.5	~19	1,530	6,120	~90	0.5	~25	1,190	5,950
			70~120	0.5	~19	1,270	4,060	90~140	0.5	~25	990	3,960
Precipitation hardening stainless steel (SUS630)	ENMU100412 ZER-SL ENMU100412 ZER-PH	JC7550 (JC8050)	~70	0.4	~19	1,270	3,560	~90	0.4	~25	990	3,470
			70~120	0.4	~19	1,150	2,760	90~140	0.4	~25	900	2,700
Duplex stainless steel (S32750)	ENMU100412 ZER-SL ENMU100412 ZER-PH	JC7550 (JC8050)	~70	0.5	~19	1,270	1,520	~90	0.5	~25	990	1,490
			70~120	0.5	~19	1,150	920	90~140	0.5	~25	900	900
Titanium alloy (Ti-6Al-4V) 35-43HRC	ENMU 100412 ZER-SL	DS150 (DS118)	~70	0.4	~19	760	2,130	~90	0.4	~25	600	2,100
			70~120	0.4	~19	640	1,540	90~140	0.4	~25	500	1,500
Heat resistant alloy (INCO718) 35-43HRC	ENMU 100412 ZER-SL	DS118 (DS150)	~70	0.3	~19	380	460	~90	0.3	~25	300	450
			70~120	0.2	~19	380	460	90~140	0.2	~25	300	450

Note

1. Please adjust cutting conditions according to machine rigidity or work rigidity.
2. In case of chatter occurring, recommended to reduce a_p or rpm and keep feed per tooth.
3. a_p should be reduced when using on low rigidity machine.
4. Use air blow.

QM MAX GII**GMX/MXG Type**

■ Recommended cutting conditions

● Facemill Type

Material	Cat.No.	Grade	Tool dia.(mm)									
			50/52					63/66				
			7N					7N				
			ℓ (mm)	a _p (mm)	a _e (mm)	n (min ⁻¹)	V _f (mm/min)	ℓ (mm)	a _p (mm)	a _e (mm)	n (min ⁻¹)	V _f (mm/min)
Carbon steel (S50C, S55C) below 250HB	ENMU 100412 ZER-PH	JC8050 (JC7560)	~150	1	~40	1,020	8,570	~150	1	~50	810	6,800
			200	0.8	~40	1,020	8,570	200	0.8	~50	810	6,800
			250	0.6	~40	890	7,480	250	0.6	~50	710	5,960
			300	0.5	~40	830	6,970	300	0.5	~50	660	5,540
			350	0.4	~40	830	6,970	350	0.4	~50	660	5,540
Tool & die steel (SKD61, SKD11) below 255HB	ENMU 100412 ZER-PH	JC8050 (JC7560)	~150	1	~40	1,020	8,570	~150	1	~50	810	6,800
			200	0.8	~40	1,020	8,570	200	0.8	~50	810	6,800
			250	0.6	~40	890	7,480	250	0.6	~50	710	5,960
			300	0.5	~40	830	6,970	300	0.5	~50	660	5,540
			350	0.4	~40	830	6,970	350	0.4	~50	660	5,540
Mold steel (HPM7, PX5, P20) 30-36 HRC	ENMU 100412 ZER-PH	JC8050 (JC7560)	~150	1	~40	1,020	8,570	~150	1	~50	810	6,800
			200	0.8	~40	1,020	8,570	200	0.8	~50	810	6,800
			250	0.6	~40	890	7,480	250	0.6	~50	710	5,960
			300	0.5	~40	830	6,970	300	0.5	~50	660	5,540
			350	0.4	~40	830	6,970	350	0.4	~50	660	5,540
Mold steel (NAK80, HPM1, P21) 38-43HRC	ENMU 100412 ZER-PH	JC8118 (JC8050)	~150	0.8	~40	540	4,160	~150	0.8	~50	430	3,310
			200	0.6	~40	540	4,160	200	0.6	~50	430	3,310
			250	0.4	~40	510	3,210	250	0.4	~50	400	2,520
			300	0.3	~40	480	3,020	300	0.3	~50	380	2,390
			350	0.3	~40	480	2,690	350	0.3	~50	380	2,130
Hardened die steel (SKD61, DAC, DHA) 42-52HRC	ENMU100412 ZER-PH (ENMU100412 ZER-SL)	JC8118 (JC7518)	~150	0.6	~40	540	4,160	~150	0.6	~50	430	3,310
			200	0.4	~40	540	4,160	200	0.4	~50	430	3,310
			250	0.2	~40	510	3,210	250	0.2	~50	400	2,520
			300	0.1	~40	510	3,210	300	0.1	~50	400	2,520
			350	—	—	—	—	350	—	—	—	—
Hardened die steel (SKD11, SLD, DC11) 55-62HRC	ENMQ100312 ZER (ENMU100312 ZER-HL)	DH102	~150	0.2	~40	510	1,070	~150	0.2	~50	400	840
			200	0.15	~40	450	790	200	0.15	~50	350	610
			250	0.1	~40	410	720	250	0.1	~50	330	580
			300	—	—	—	—	300	—	—	—	—
			350	—	—	—	—	350	—	—	—	—
Grey cast iron (FC250) 160-260HB	ENMU 100412 ZER-PH	JC8118 (JC8050)	~150	1	~40	1,150	12,080	~150	1	~50	910	9,560
			200	0.8	~40	1,150	12,080	200	0.8	~50	910	9,560
			250	0.6	~40	1,020	10,710	250	0.6	~50	810	8,510
			300	0.5	~40	950	9,980	300	0.5	~50	760	7,980
			350	0.4	~40	950	7,980	350	0.4	~50	760	6,380
Nodular cast iron (FCD700) 170-300HB	ENMU 100412 ZER-PH	JC8118 (JC8050)	~150	1	~40	1,150	12,080	~150	1	~50	910	9,560
			200	0.8	~40	1,150	12,080	200	0.8	~50	910	9,560
			250	0.6	~40	1,020	10,710	250	0.6	~50	810	8,510
			300	0.5	~40	950	9,980	300	0.5	~50	760	7,980
			350	0.4	~40	950	7,980	350	0.4	~50	760	6,380

Note

1. Please adjust cutting conditions according to machine rigidity or work rigidity.
2. In case of chatter occurring, recommended to reduce a_p or rpm and keep feed per tooth.
3. a_p should be reduced when using on low rigidity machine.
4. Use air blow.

QM MAX GII**GMX/MXG Type**

■ Recommended cutting conditions

● Facemill Type

Material	Cat.No.	Grade	Tool dia.(mm)									
			50/52					63/66				
			7N					7N				
			ϕ (mm)	a_p (mm)	a_e (mm)	n (min ⁻¹)	V_f (mm/min)	ϕ (mm)	a_p (mm)	a_e (mm)	n (min ⁻¹)	V_f (mm/min)
Austenitic stainless steel (SUS304, 316, 317) 17Cr	ENMU 100412 ZER-SL	JC8050 (JC7518)	~150	0.8	~40	760	5,320	~150	0.8	~50	610	4,270
			200	0.6	~40	760	5,320	200	0.6	~50	610	4,270
			250	0.4	~40	640	4,480	250	0.4	~50	510	3,570
			300	0.3	~40	640	4,480	300	0.3	~50	510	3,570
			350	0.3	~40	640	3,580	350	0.3	~50	510	2,860
Precipitation hardening stainless steel (SUS630)	ENMU100412 ZER-SL ENMU100412 ZER-PH	JC7550 (JC8050)	~150	0.6	~40	640	3,140	~150	0.6	~50	510	2,500
			200	0.5	~40	640	3,140	200	0.5	~50	510	2,500
			250	0.3	~40	570	2,790	250	0.3	~50	450	2,210
			300	0.2	~40	570	2,790	300	0.2	~50	450	2,210
			350	0.2	~40	570	2,390	350	0.2	~50	450	1,890
Duplex stainless steel (S32750)	ENMU100412 ZER-SL ENMU100412 ZER-PH	JC7550 (JC8050)	~150	0.8	~40	640	1,340	~150	0.8	~50	510	1,070
			200	0.6	~40	640	1,340	200	0.6	~50	510	1,070
			250	0.4	~40	570	1,200	250	0.4	~50	450	950
			300	0.3	~40	570	1,200	300	0.3	~50	450	950
			350	0.3	~40	570	800	350	0.3	~50	450	630
Titanium alloy (Ti-6Al-4V) 35-43HRC	ENMU 100412 ZER-SL	DS150 (DS118)	~150	0.7	~40	380	1,860	~150	0.7	~50	300	1,470
			200	0.5	~40	380	1,860	200	0.5	~50	300	1,470
			250	0.3	~40	320	1,570	250	0.3	~50	250	1,230
			300	0.3	~40	320	1,570	300	0.3	~50	250	1,230
			350	0.3	~40	320	1,340	350	0.3	~50	250	1,050
Heat resistant alloy (INCO718) 35-43HRC	ENMU 100412 ZER-SL	DS118 (DS150)	~150	0.7	~40	190	400	~150	0.7	~50	150	320
			200	0.5	~40	190	400	200	0.5	~50	150	320
			250	0.3	~40	160	340	250	0.3	~50	130	270
			300	0.2	~40	160	340	300	0.2	~50	130	270
			350	0.2	~40	130	270	350	0.2	~50	100	210

Note

1. Please adjust cutting conditions according to machine rigidity or work rigidity.
2. In case of chatter occurring, recommended to reduce a_p or rpm and keep feed per tooth.
3. a_p should be reduced when using on low rigidity machine.
4. Use air blow.